



Accumulation Solutions

Nercon's conveyor accumulation loop is designed as a buffer zone for upstream or downstream production efficiencies. The accumulation loop allows the upstream and downstream applications to work independently of each other creating a helpful buffer zone between processes that require different lengths of time to complete preventing congestion.

With minimum back pressure, the accumulation loop is ideal for a large volume of rigid items that share the same weight and dimensions minimizing damage on products.

FEATURES

- Smooth combining
- Gentle on products
- Modular design
- Adjustable divert arm
- Low maintenance requirements

INDUSTRY SEGMENTS

- Snack Food & Bakery
- Packaged Foods
- Beverage
- Confectionery & Candy
- Dairy Food
- Health & Beauty
- Household Cleaning Products
- Pharmaceuticals

APPLICATION TYPES

- Bottles
- Bowls
- Canisters
- Cans
- Cups
- Jars
- Rounded Trays

Accumulation Loop

Dynamic Transfer Section vs Dead Plate

A solution for Nercon conveyor turns, the Dynamic Transfer Section allows manufacturers to make tighter turns in a smaller floor space. Capable of handling a variety of product sizes, types, and

shapes, the dynamic transfer section features a smooth, live transfer without the use of a dead plate, keeping even the last products moving and ensuring product stability and integrity.

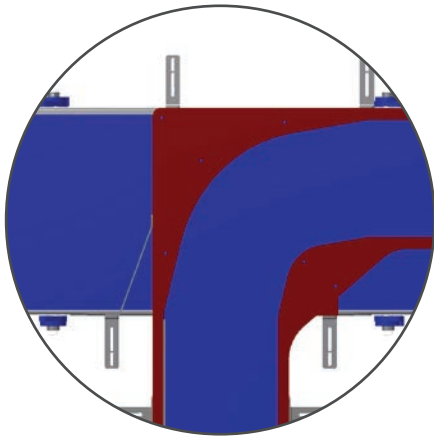

DTS

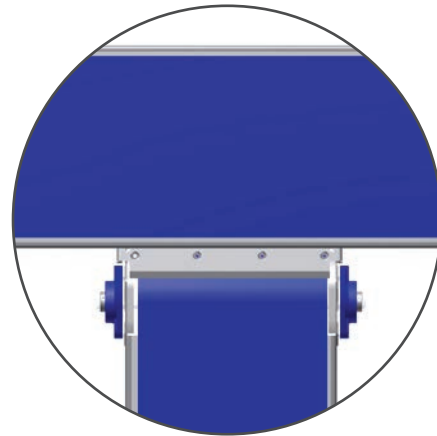

Dead Plate

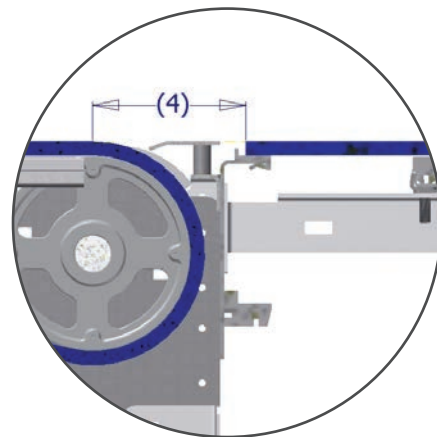
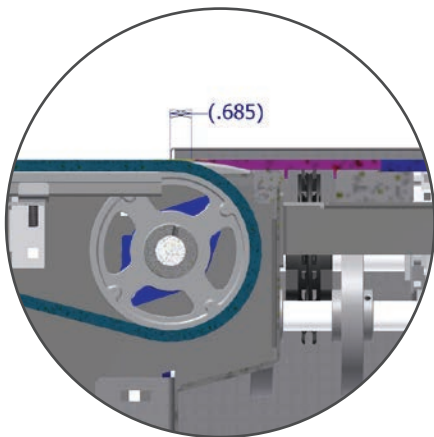

For more information and videos about Nercon's conveyor systems visit our website: www.nerconconveyors.com



Subscribe to Nercon's Blog
www.nerconconveyors.com

Made in the U.S.A. 



600 S. Commercial Street | Neenah WI 54956
toll free 844-293-2814 | www.nerconconveyors.com

© 2018 Nercon, Inc. All rights reserved. 10/20 000 SELL-ACCUMLOOP